

DS18[®]

5XE

OWNER'S MANUAL
MANUAL DE USUARIO

S65

6.5" 2-WAY COAXIAL SPEAKERS

ALTAVOZ COAXIAL DE 6.5" DE 2 VIAS

4Ω

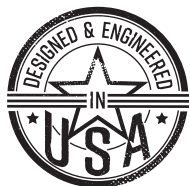

ENGLISH | ESPAÑOL



S65

INSTALLATION

Refer to your car stereo owner's manual.

INSTALACIÓN

Consulte el manual del propietario del estéreo de su automóvil.

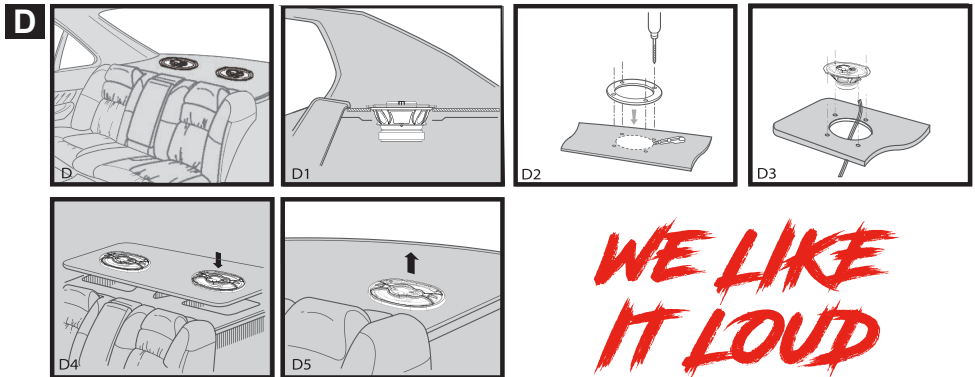
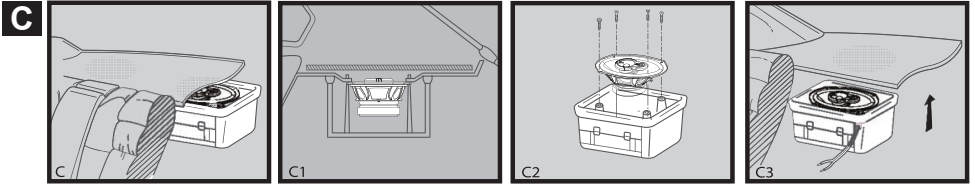
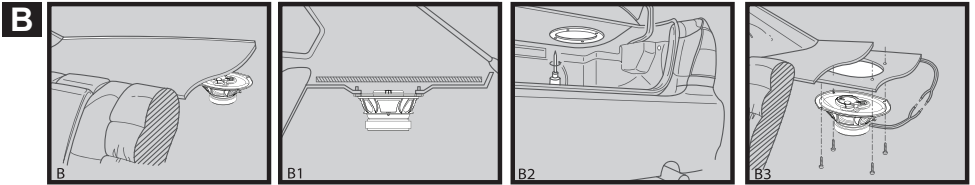
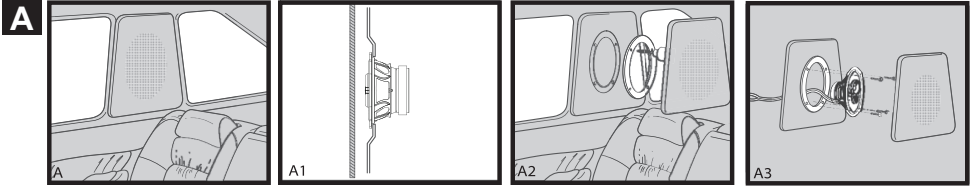

**WE LIKE
IT LOUD**

S65



6.5" 2-WAY COAXIAL SPEAKER

ALTAVOZ COAXIAL DE 6.5" DE 2 VIAS

SPECIFICATIONS / ESPECIFICACIONES

Nominal Diameter / Diámetro Nominal	6.5" / 165mm
Nominal Impedance / Impedancia Nominal	4 OHM
RMS Power Handling / Manejo de Potencia RMS	60W
MAX Power Handling / Manejo de Potencia MAX	180W
Sensitivity (1w/1m) / Sensibilidad (1w/1m)	88.5dB
Frequency Response / Respuesta de Frecuencia	35Hz-20KHz
Recommended HI Pass Crossover / Crossover Paso alto Recomendado	60Hz
Number of Ways / Número de Vias	2
Pair or Single / Par o Unidad	Pair / Par
Grill Included / Parrilla Incluida.....	Yes / Si

WOOFER / WOOFER

Voice Coil Diameter / Diámetro de la Bobina de Voz.....	1" / 25.5mm
Voice Coil Former Material / Material Interior de Bobina Móvil	ASV
Winding Material / Material de Bobinado.....	EISV
Cone Material / Material del Cono	PPI
Surround Material / Material de la Suspensión	Rubber / Goma
Basket Material / Material de la Canasta	Steel / Acero
Basket Color / Color de la Canasta.....	Black Matte / Negro mate
Magnet Material / Material del Imán.....	Barium Ferrite / Ferrita de bario
Magnet Weight / Peso del Imán	80z / 227g

TWEETER / TWEETER

Nominal Diameter / Diámetro Nominal	1" / 25.5mm
Voice Coil Diameter / Diámetro de la Bobina de Voz.....	0.5" / 13.25mm
Voice Coil Former Material / Material Interior de Bobina Móvil	ASV
Winding Material / Material de Bobinado	EISVM
Diaphragm Material / Material del Diafragma	Mylar
Magnet Material / Material del Imán	Neodymium / Neodimio
Magnet Weight / Peso del Imán.....	1.8g

THIELE & SMALL PARAMETERS / PARÁMETROS T/S

Equivalent Volume / Volumen Equivalente	Vas	8.25L / 0.29ft3
Excursion (one way) / Excursión (1 vía).....	Xmax	2.7mm
Free Air Resonance / Resonancia al Aire Libre.....	Fs	70Hz
Mechanical Factor / Factor Mecánico	Qms	6.09
Electrical Factor / Factor Eléctrico.....	Qes.....	1.93
Total Factor / Factor Total	Qts	1.47
Mechanical Mass / Masa Mecánica.....	Mms.....	11.4g
Mechanical Compliance / Cumplimiento Mecánico.....	Cms	320mm/N
BL Factor / Factor BL	BL	3.96
Voice Coil Inductance / Inductancia de Bobina de Voz	Le	187uH
Cone Area / Área del Cono	Sd	136.8cm2
DC Resistance / Resistencia DC	Re.....	3.4 Ohms
Mechanical Mass w/o air / Masa mecánica	Mmd	12g

MEASUREMENTS / MEDIDAS

Overall Diameter / Diámetro Total	6.5" / 165mm
Overall Depth / Profundidad Total.....	2.3" / 58.5mm
Overall Diameter with Grill / Diámetro Total con Parrilla.....	7" / 179mm
Overall Depth with Grill / Profundidad Total con Parrilla	3" / 77mm
Front Mount Baffle Cutout / Corte del Orificio de Montaje	5.6" / 143mm
Mounting Depth / Profundidad de Montaje	2" / 53mm
Motor Diameter / Diámetro del Motor	3.15" / 80mm
Tweeter Protrusion / Protuberancia del Tweeter.....	0.25" / 6.4mm

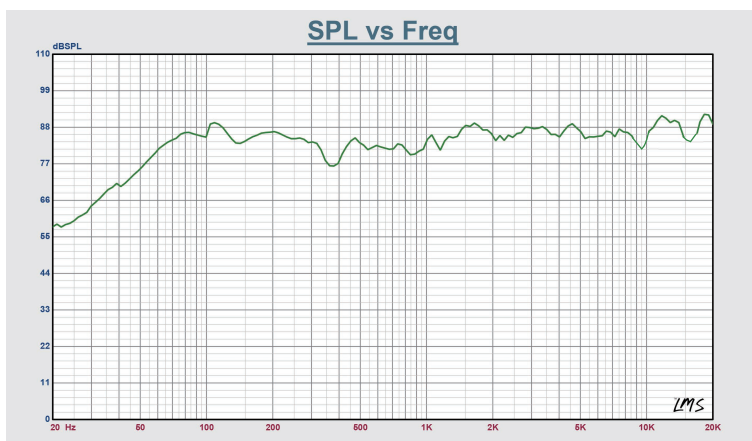

MEASUREMENTS WITH GRILL / MEDIDAS CON PARRILLA:

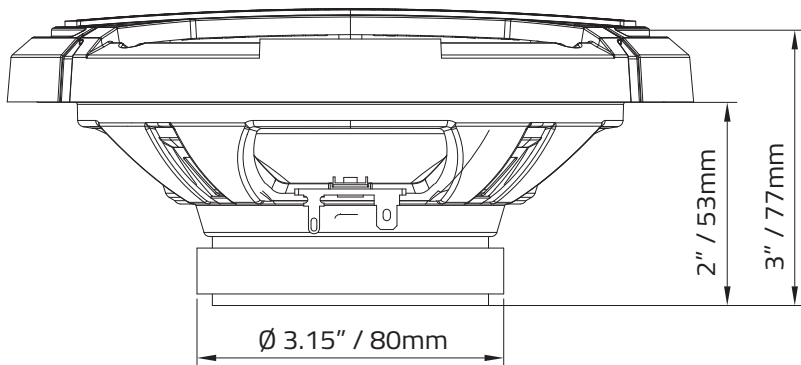
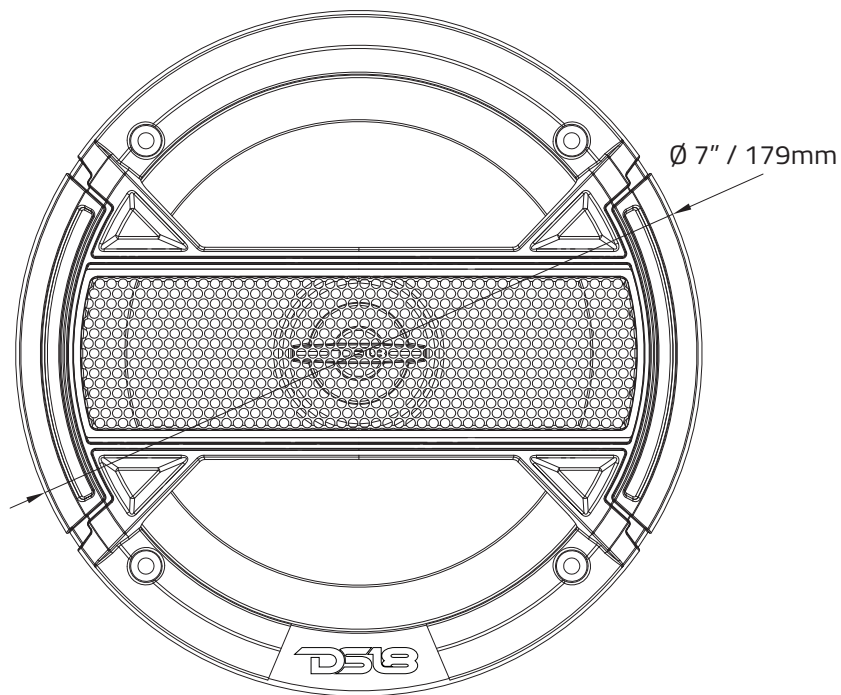

MEASUREMENTS / MEDIDAS:

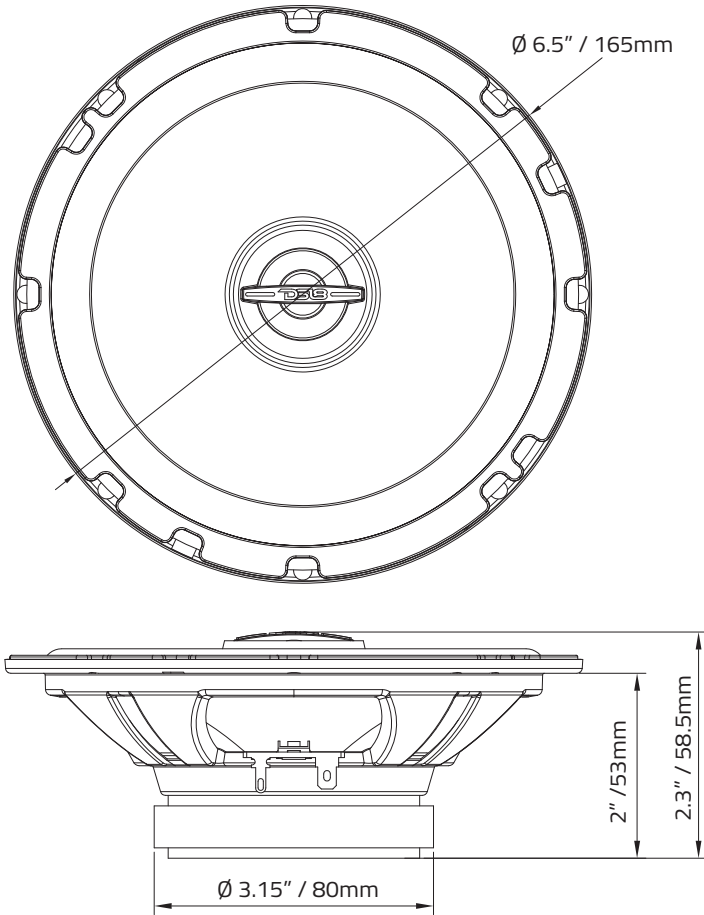

WARRANTY

Please visit our website DS18.com for more information on our warranty policy.

We reserve the right to change products and specifications at any time without notice. Images may or may not include optional equipment.

GARANTÍA

Visita nuestra página web DS18.com para obtener más información sobre nuestra garantía.

Nos reservamos el derecho de cambiar productos y especificaciones en cualquier momento sin previo aviso. Las imágenes pueden incluir o no equipo opcional.



WARNING:

Cancer and Reproductive Harm.
www.P65Warning.ca.gov



ADVERTENCIA:

Cáncer y Daño Reproductivo.
www.P65Warning.ca.gov

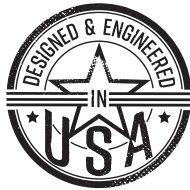

FOR MORE INFORMATION
PLEASE VISIT
DS18.COM

WE LIKE IT LOUD

DS18[®]