

**A time to look back.
A time to look forward.**

Morel's story was born 45 years ago. For our founder - my father Meir - and me, these past four and a half decades have been a life-altering journey. Till this day, I take pride that we uphold the very values we began with: an emphasis on handcrafted production and unleashing the raw emotions that music reveals. Because even in our humble beginnings, creating "ordinary" audio equipment just wasn't in our DNA. Some people call this innovation, but for us it's just the way we've always worked, continually pushing the boundaries of audio.

Enjoy the ride. Unleash the music.

Yours truly,
Oren Mordechai
CEO





Erasing the boundaries

Erasing the boundaries between artist and listener is at the core of our ethos. With a highly detailed approach to handmade craftsmanship and innovation, we deliver a sound that seamlessly fuses form with function. For the last four and a half decades, we have been driven by the desire to recreate the raw emotions of live music experiences. Our latest line of products will immerse you in a moment where the musicians are playing just for you. The power of sound is so immense, it can make your heartbeat quicken, embolden you to give in to your emotions and connect to your love for music. When Morel unleashes the music, you are always in the front row.

The Art of Sound

For our 45th anniversary, Morel collaborated with Miriam Cabessa, a renowned Israeli and NY-based contemporary artist, to bring to life the movement of sound. While the physicality of sound remains unseen, Cabessa sought to viscerally present it: with Morel speakers submerged in gold liquid, sound waves reverberated throughout the liquid, creating ripples reflective of the frequency of sound. Cabessa's works are known for interpreting movement through dynamic flow and rhythm. Her work, displayed throughout our catalogue, sheds a unique light onto the experience of Morel. It is an almost spiritual experience, just like the one we seek with every product that we build.

unleash **the music**



RESOLUTION

Engineered to reproduce music
to the most exacting standards

SUPREMO

Crafting speakers to perform with lifelike detail takes creativity, dedication, and an expanse of technical knowledge. Morel has been perfecting this craft for 48 years, culminating in the flagship Supremo systems which take high resolution audio to levels not yet experienced in the automotive world.

Morel's recipe for success is based on a no-compromise design using the pinnacle of Morel technology. The woofers blend powerful neodymium magnets with our EVC (External Voice Coil) motor topology, an underhung 3" (76mm) diameter Hexatech™ aluminum voice coil, and a proprietary carbon fiber and Rohacell sandwich cone. These combine to create lightning quick transient response and dynamic sound reproduction. High-frequency details resonate from the exquisite Supremo Piccolo tweeter, which is lauded around the globe for its unrivaled open and detailed responsiveness.

Maintaining the Resolution namesake, the Supremo effortlessly produces the finest details, precisely as the music was intended to be heard. Crisp, clear musicality; deep, powerful tonality; and subtleties which reveal themselves delightfully to listener's ears. Even the most discerning audiophiles will find themselves seduced by the Supremo.

With the Supremo system, you're not just listening to top-tier car audio technology - you're tapping into a 48 year legacy. Enjoy the ride.

MODEL	SIZE & CONFIGURATION	POWER HANDLING (WRMS)	PEAK POWER (W)	SENSITIVITY (2.83V/1M) (DB)	FREQUENCY RESPONSE (HZ)	CROSSOVER
Supremo 602	6½" 2-way	140	600	89	40-25000	MXR Supremo
Supremo 602 Active	6½" 2-way	140	600	89	40-25000	



ULTIMO TITANIUM

Powerful. Dynamic. Musical. Three simple words which perfectly describe the Ultimo Titanium. The Ultimo Titanium was engineered to reproduce bass so musically accurate that it would have no equal.

Ultimo Titanium subwoofers are equipped with Morel's most advanced technology derived from its Hi-Fi bass drivers. At their core lies the EVC motor design with an extremely large 5.1" (130mm) Hexatech™ aluminum voice coil attached to a titanium voice coil former – the first of its kind in car audio. The massive magnet creates unparalleled efficiency - nearly 90% as opposed to 60% on comparable systems - while the giant voice coil moves the speaker cone with unmatched precision. Exceptionally stiff and lightweight, the titanium improves driver dynamics for even quicker transient response. An additional copper magnet cap stabilizes the magnetic field while increasing the linear response and reducing distortion.

The subwoofer is topped off with a beautiful two-layer woven carbon fiber and paper composite cone. Extremely stiff and highly damped, it moves air with precision and authority, without experiencing breakup or distortion.

The culmination of Morel's technological advancements resulted in the Ultimo Titanium. It's simply the most dynamic car audio subwoofer Morel has engineered, providing the highest resolution in bass reproduction. It's powerful. It's dynamic. And it's a musical delight.

MODEL	UNIT SIZE (Inch)	NOMINAL IMPEDANCE (OHMS)	POWER HANDLING (WRMS)	PEAK POWER HANDLING (10MS) (W)	SENSITIVITY (2.83V/1M) (dB)	FREQUENCY RESPONSE (Hz)
Ultimo Ti 122	12" Diameter	2	1000	3000	87	10-900
Ultimo Ti 124	12" Diameter	4	1000	3000	86.3	10-900
Ultimo Ti 102	10" Diameter	2	1000	3000	86.1	10-900
Ultimo Ti 104	10" Diameter	4	1000	3000	85	10-900
Ultimo Ti 802	8" Diameter	2	800	3000	84	20-900
Ultimo Ti 804	8" Diameter	4	800	3000	83.7	20-900





REFERENCE

Ultimate synergy of sound quality
and power handling



morel

ELATE CARBON PRO

The Elate Carbon Pro is the purest evolution of our iconic Elate line, continuing to push the boundaries of automotive audio performance. With refined aesthetics, revamped construction, and Morel's storied handcrafted essence, we're taking the Elate series higher than it's ever been before.

The new speaker systems maintain the Elate's high power, high fidelity tradition, yet with massive upgrades in design and materials. We've equipped it with a triple-layered carbon-fiber/Rohacell cone for midrange and woofers, titanium voice coils, our iconic Lotus grills and a brushed aluminum trim. The Elate Carbon Pro is highlighted by the Elate Alto cavity-back tweeter, employing a high-resolution design borrowed from the Supremo Piccolo's architecture.

These upgrades give the new systems a leap forward in performance. Alongside a widened, three-dimensional soundstage with greater frequency response, the Elate Carbon Pro's ability to produce exquisite details, at any volume level, is simply breathtaking. At Morel, we always focus on presenting sound as the artist intended. With a neutral balance and immersive depth, the Elate Carbon Pro brings listeners closer to the artist.

From the outset, we developed the Elate Carbon Pro to be more than just a new set of speakers – they were designed to provide Morel customers an immersive musical experience that will leave you breathless. No other speaker system fully represents high power, high fidelity like the new Elate Carbon Pro. Once you've experienced them, we're confident you'll agree.

MODEL	SIZE & CONFIGURATION	POWER HANDLING (WRMS)	PEAK POWER (W)	SENSITIVITY (2.83V/1M) (dB)	FREQUENCY RESPONSE (Hz)	CROSSOVER (Optional)
Elate Carbon Pro 53A	5¼" 3-way	160	1000	85	40-25000	MXT380C
Elate Carbon Pro 63A	6½" 3-way	180	1000	87	30-25000	MXT380C
Elate Carbon Pro 93A	9" 3-way	200	1000	89	25-25000	MXT380C
Elate Carbon Pro 52A	5¼" 2-way	160	1000	85	40-25000	MXT280C
Elate Carbon Pro 62A	6½" 2-way	180	1000	87	30-25000	MXT280C



ELATE CARBON

The Elate Carbon continues the legacy of the iconic high power, high fidelity Elate line by bringing ultimate performance to install-friendly systems. While the Elate Carbon shares most of its high-end componentry with the Elate Carbon Pro, it takes on a slightly smaller form factor for those who value discreteness but don't want to sacrifice performance.

Unique to the Elate Carbon are the compact MT450 tweeters which can easily fit into most OEM factory locations or space-limited areas using the supplied mounts. Built with an Acuflex™ coated silk dome, open cavity design, and dual neodymium magnet motor, the MT450's produce amazing detail and a silky-smooth, flat frequency response.

The new Elate Carbon woofers continue to bring serious power. Whether choosing a 5.25", 6.5" or 9" woofer, each features FEA and Klippel-optimized EVC motors with large 3" (75mm) diameter voice coils and Morel's proprietary TLC (Triple Layer Composite) carbon fiber/Rohacell sandwich cones, yielding ultra-low distortion and high power handling.

The Elate Carbon 3-way systems feature the all new MM3 3.5" (89mm) cone midrange. Using top-of-the-line Morel technology such as an EVC motor, high power 2.1" (53mm) diameter voice coil, and a highly damped TLC carbon-fiber/Rohacell cone. The result is even greater control in lower frequencies than larger 4.5" speakers, while still able to fit into most OEM midrange locations.

Handcrafted as always, and with a vast feature set, spectacular sound performance and compact design, the new Elate Carbon will blow your expectations away.

MODEL	SIZE & CONFIGURATION	POWER HANDLING (WRMS)	PEAK POWER (W)	SENSITIVITY (2.83V/1M) (dB)	FREQUENCY RESPONSE (Hz)	CROSSOVER (Optional)
Elate Carbon 53A	5¼" 3-way	160	1000	85	40-25000	MXT380C
Elate Carbon 63A	6½" 3-way	180	1000	87	30-25000	MXT380C
Elate Carbon 93A	9" 3-way	200	1000	89	25-25000	MXT380C
Elate Carbon 52A	5¼" 2-way	160	1000	85	40-25000	MXT280C
Elate Carbon 62A	6½" 2-way	180	1000	87	30-25000	MXT280C

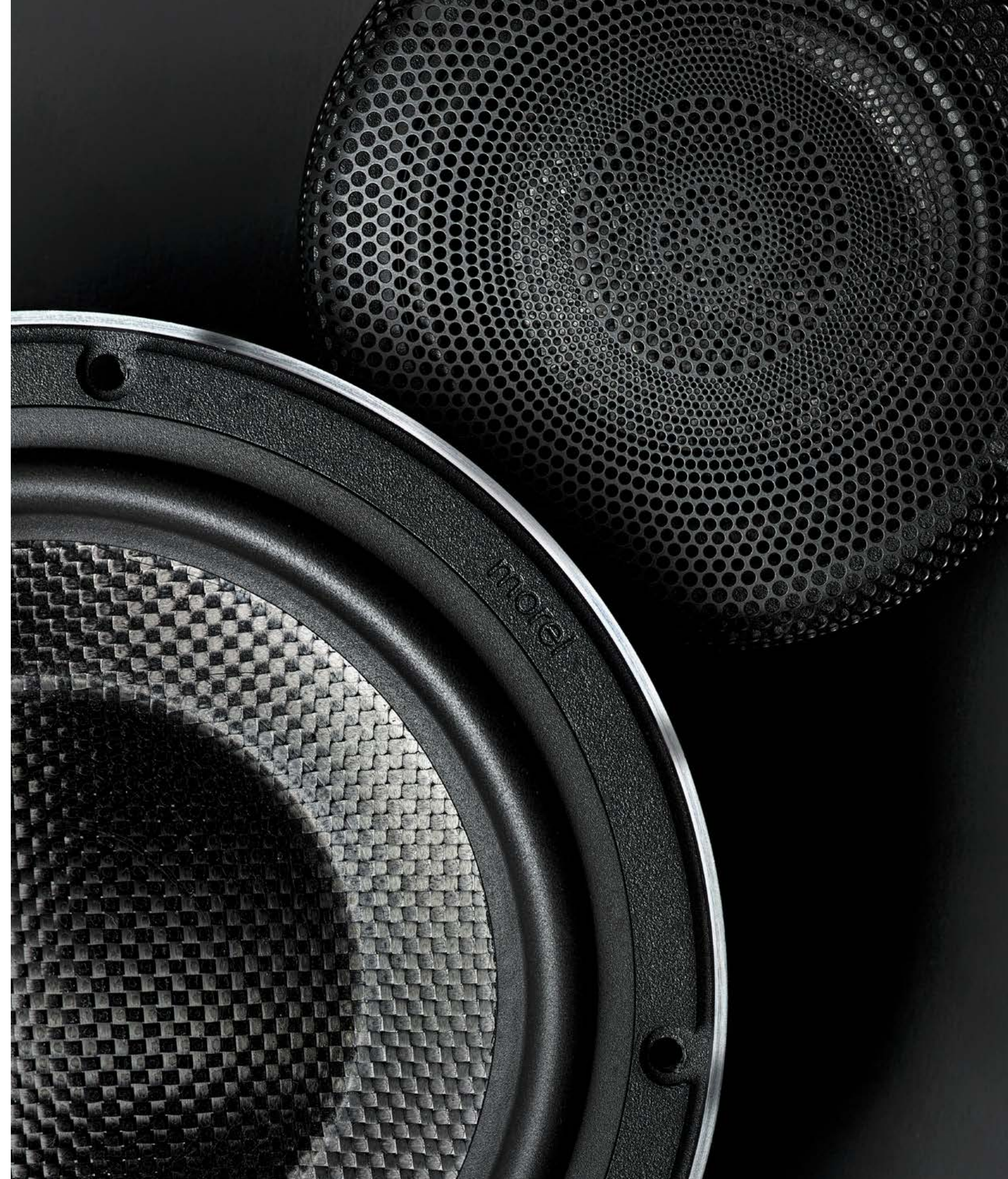

HYBRID

Embracing Morel's legendary craftsmanship, engineering and innovation, the latest Hybrid systems define our ever-evolving concept of high-fidelity speaker design. Now in their fifth generation, the new Hybrid systems provide a further refined listening experience. Their subtle balance of resolution, power and efficiency has been optimized to evoke raw emotions, regardless of the music genre.

The Hybrid line is available in 2-way, 3-way and Integra point source solutions, creating optimal sound coherency regardless of your speaker requirements..

Hybrid continues to provide top level Morel technology. Each midrange and woofer comes equipped with a 2.1" (54mm) Hexatech™ aluminum EVC, a DPC one-piece cone architecture, hybrid and double magnet motors. A new handcrafted MT300 soft dome tweeter employs our innovative Acuflex™ technology, producing a natural, non-fatiguing listening experience. In 3-way systems, our new CDM700 is a perfect midrange compliment, designed to work flawlessly with the MT300 and Hybrid woofers. The line is styled with a beautiful brushed aluminum trim, an external aesthetic which compliments its elegant internal componentry.

The Integra, Morel's point source system, is an innovative landmark in speaker design. It utilizes point-source topology to eliminate acoustic problems inherent in conventional coaxial systems. By creating a single sound source on the same axis, the tweeter and woofer seamlessly integrate, generating omni-directional time alignment, heightened imaging and sound dispersion.

Going eighteen years strong, the Hybrid line continues to exceed expectations. This latest evolution showcases how far we intend on taking it.

MODEL	SIZE & CONFIGURATION	POWER HANDLING (WRMS)	PEAK POWER (W)	SENSITIVITY (2.83V/1M) (dB)	FREQUENCY RESPONSE (Hz)	CROSSOVER
Hybrid 63	6½" 3-way	140	600	91	35-25000	MXR300.4
Hybrid 42	4" 2-way	100	300	89	50-25000	MXR240.4
Hybrid 52	5¼" 2-way	120	500	90	45-25000	MXR240.4
Hybrid 62	6½" 2-way	140	600	91	35-25000	MXR240.4
Hybrid integra 42	4" Point Source	80	250	92	80-25000	MXR250.4i
Hybrid Integra 52	5¼" Point Source	90	250	90	70-25000	MXR250.4i
Hybrid Integra 62	6½" Point Source	100	300	91	65-25000	MXR250.4i



VIRTUS NANO CARBON

The Virtus Nano Carbon is a one-of-a-kind speaker system which will transform your drives into multi-sensory musical experiences. Their ultra-slim design exemplifies our innovative quest to push acoustic and mechanical boundaries, while offering practical solutions to car audio enthusiasts.

The cutting edge design of the Virtus Nano Carbon line combines top level technology in an ultra-slim profile that can fit where comparable speakers can't. Both the 4" and 6.5" speakers woofers come in at only 0.7" (17mm) deep, making them the shallowest car audio speakers available in the market. This engineering feat uses innovative suspension design, a highly powerful neodymium magnet system, a 2.1" (54mm) Hexatech aluminum voice coil and Grand Dome carbon-fiber sandwich cone.

The Virtus Nano Carbon delivers benchmark level performance in 2-way, 3-way and Integra point source systems. While they are the perfect speaker where mounting depth is a concern, their performance is markedly better than traditional speaker designs. Their dynamic range and rich bass will engage you while the detailed and natural sound will allow you to "see" the music as its intended. Sleek and aurally engaging, the Virtus Nano Carbon is a treat to both your eyes and ears.

Registered U.S. Patent No. 11,057,696

MODEL	SIZE & CONFIGURATION	POWER HANDLING (WRMS)	PEAK POWER (W)	SENSITIVITY (2.83V/1M) (dB)	FREQUENCY RESPONSE (Hz)	CROSSOVER
Virtus Nano Carbon 63	6½" 3-way	100	300	88	50-25000	MXR130
Virtus Nano Carbon 42	4" 2-way	90	300	88	80-22000	MXR200.4
Virtus Nano Carbon 62	6½" 2-way	100	300	88	50-25000	MXR200.4
Virtus Nano Carbon Integra 42	4" Point Source	80	300	87	90-25000	MXR250.4i
Virtus Nano Carbon Integra 62	6½" Point Source	100	300	87	50-25000	MXR250.4i



ULTIMO TITANIUM SC

Developed with Morel's Performance philosophy in mind, the Ultimo Titanium SC delivers innovative engineering, audiophile sound quality and high power output, all at a great consumer value.

The Ultimo Titanium SC subwoofers borrow some of the best technological features from their high-end Ultimo Titanium siblings. This includes the gigantic 5.1" (13mm) Hexatech™ voice coil and titanium former, as well as the beautiful two-layer woven carbon fiber and paper composite cone. A highly efficient magnet motor system with Morel's DMM (Double Magnet Motor) and EVC design maximizes the magnetic field efficiency, decreases distortion and increases power handling for the most demanding applications. All this is enclosed in an attractive and sleek steel chassis.

With the Ultimato Titanium SC, start experiencing bass as it was meant to sound.

MODEL	UNIT SIZE (Inch)	NOMINAL IMPEDANCE (OHMS)	POWER HANDLING (WRMS)	PEAK POWER HANDLING (10MS) (W)	SENSITIVITY (2.83V/1M) (dB)	FREQUENCY RESPONSE (Hz)
Ultimo Ti SC 122	12" Diameter	2	600	2000	87	10-900
Ultimo Ti SC 124	12" Diameter	4	600	2000	87	10-900
Ultimo Ti SC 102	10" Diameter	2	600	2000	86	10-900
Ultimo Ti SC 104	10" Diameter	4	600	2000	86	10-900



MPS LIMITED AMPLIFIERS

For the true audiophile who seeks fidelity and power, we introduce you to the MPS LIMITED amplifiers.

Developed to the highest standards to celebrate Morel's 45th anniversary, two models consisting of a 2-channel class AB and a class D monoblock utilize audiophile-grade components, including Burr-Brown OPA2134 op-amps, Rubicon and WIMA ultra-low ESR capacitors, Sanken output transistors, gold plated connections, and chassis-mounted RCA connections. Noise eliminating balanced line inputs accept signal up to 20 volts.

Removable side panel plates allow for unique mounting options and enable amplifiers to be stacked together to minimize their footprint.

This superior design and construction give the MPS LIMITED the power and performance to drive any Morel system to its maximum.

MPS LIMITED AMPLIFIERS	MPS 1.1100 LIMITED	MPS 2.150 LIMITED	
		High Power	High Current
RMS POWER @ 14V			
4 Ohm	1 x 650W	150W x 2	100W x 2
2 Ohm	1 x 1,100W	N/A	150W x 2
SPECIFICATIONS			
THD+N	0.10%		0.02%
Frequency Response (+/-1dB)	10Hz-220Hz		10Hz-80kHz
S/N Ratio (Rated Power, A-weighted)	102dB		111dB
Channel Separation	N/A		68dB
Damping Factor	>200		>250
Selectable Input Range	Yes (x1/x4)		Yes (x1/x2)
PREAMP			
Filter	LP, 40Hz-220Hz		N/A
Subsonic Filter	OFF/25Hz/35Hz		N/A
Subwoofer Level Control	Optional MPS-RI, 0-20dB		N/A
Pass-Through Preamp Output	YES		N/A
DIMENSIONS			
Height (H)	2" (51mm)		2" (51mm)
Width (W)	6.7" (170mm)		6.7" (170mm)
Length (L)	12.65" (322mm)		12.65" (322mm)





PERFORMANCE

—
All the virtues and sound of Morel
in affordable packages



TEMPO ULTRA MKII

The Tempo Ultra MKII is the perfect line for music aficionados who demand outstanding performance for value, all with the same Morel quality you've come to know and love.

The Tempo Ultra MKII features both 2-way component and Integra point source solutions, creating flexible options for diverse setups. Each component system comes equipped with handcrafted 1.1" (28mm) soft dome tweeters and woofers with oversized voice coils and robust magnet systems.

The oversized 1.5" (38mm) diameter voice coil gives Tempo Ultra MKII outstanding power handling - up to 40% higher than the competition - while maintaining low distortion levels. This also allows them to deliver phenomenal bass, giving listeners a full response without the need for a subwoofer. Combined with aforementioned soft dome tweeters, listeners will enjoy Morel's signature tonal balance, accurate detail and vocal range for a truly memorable musical experience.

The Tempo Ultra MKII's value is undeniable. Let them take you higher.

MODEL	SIZE & CONFIGURATION	POWER HANDLING (WRMS)	PEAK POWER (W)	SENSITIVITY (2.83V/1M) (dB)	FREQUENCY RESPONSE (Hz)
Tempo Ultra 502 MKII	5¼" 2-way	110	250	89	65-22000
Tempo Ultra 602 MKII	6½" 2-way	130	250	90	55-22000
Tempo Ultra 572 MKII	5x7" 2-way	120	250	90	60-22000
Tempo Ultra 692 MKII	6x9" 2-way	150	280	91	50-22000
Tempo Ultra Integra 402 MKII	4" Point source	80	140	85	80-22000
Tempo Ultra Integra 502 MKII	5¼" Point source	100	220	89	55-22000
Tempo Ultra Integra 602 MKII	6½" Point source	120	220	90	50-22000
Tempo Ultra Integra 572 MKII	5x7" Point source	110	220	90	60-22000
Tempo Ultra Integra 692 MKII	6x9" Point source	150	250	92	50-22000

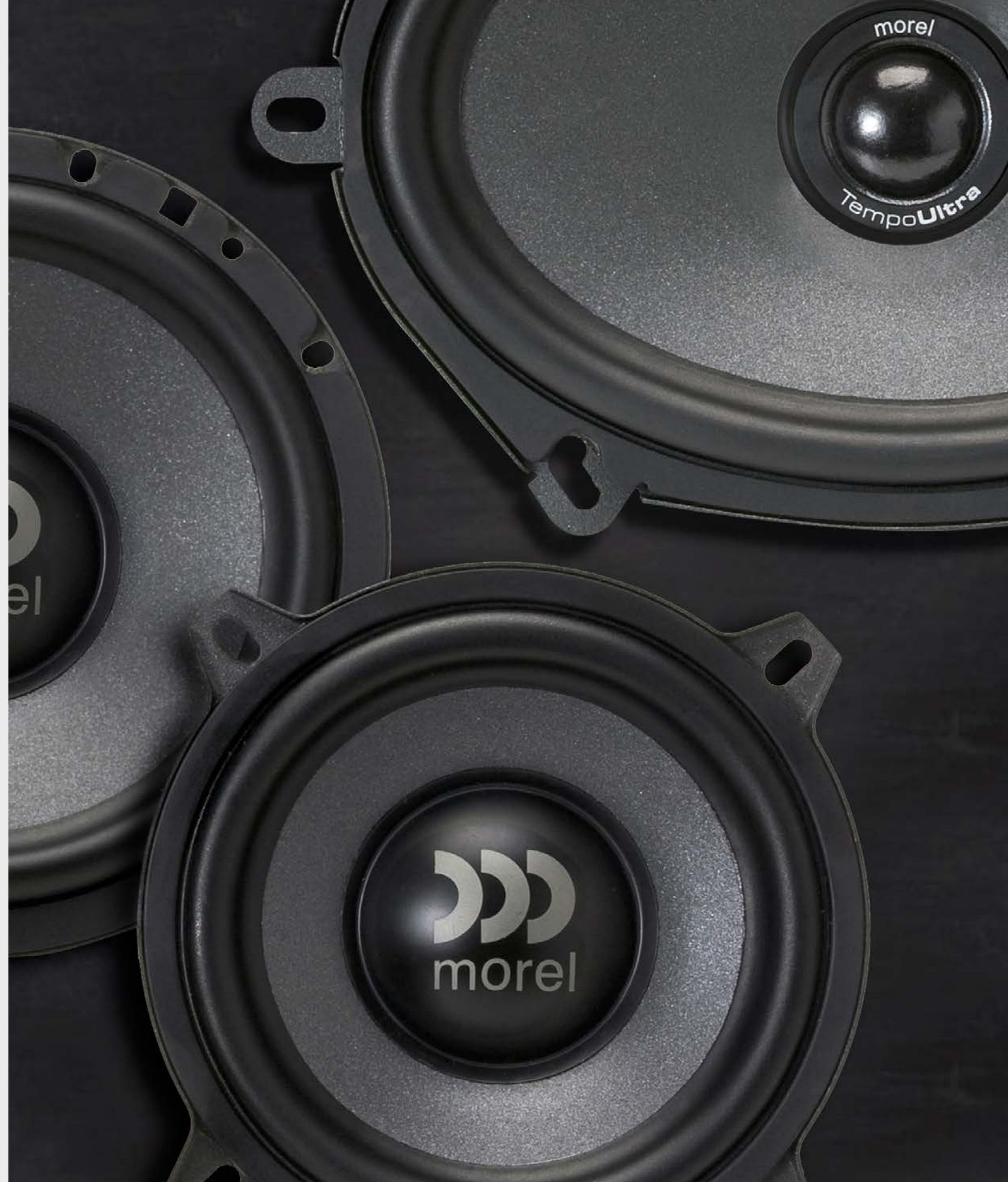



MAXIMO ULTRA MKII

Let your Morel journey begin with the Maximo Ultra MKII. Following Morel's philosophy of developing the industry-leading music systems, the Maximo Ultra MKII series shares our design principles at an affordable price.

Each kit was engineered to be easily installed in original speaker locations and to be integrated with factory head units or used with an aftermarket amplifier. Whether your vehicle uses coaxials, or 2 or 3-way components, Maximo Ultra MKII has you covered.

Regardless of what you drive or what genre you listen to, the high value Maximo Ultra MKII will vastly enhance your listening experience. Welcome to the Morel family.

MODEL	SIZE & CONFIGURATION	POWER HANDLING (WRMS)	PEAK POWER (W)	SENSITIVITY (2.83V/1M) (dB)	FREQUENCY RESPONSE (Hz)
Maximo Ultra 603 MKII	6½" 3-way	100	180	90.5	50-20000
Maximo Ultra 502 MKII	5¼" 2-way	90	160	89	50-20000
Maximo Ultra 602 MKII	6½" 2-way	100	180	90.5	50-20000
Maximo Ultra 602HE MKII	6½" 2-way	100	180	94	60-20000
Maximo Ultra Coax 402 MKII	4" Coaxial	50	100	87.5	75-20000
Maximo Ultra Coax 502 MKII	5¼" Coaxial	80	140	89.5	55-20000
Maximo Ultra Coax 602 MKII	6½" Coaxial	90	160	91	55-20000
Maximo Ultra Coax 692 MKII	6x9" Coaxial	110	200	92	45-20000





PRIMO

The Primo was engineered to offer Morel build and sound quality at an exceptional value. This Performance-line subwoofer is both accessible to consumers while remaining versatile and providing excellent sound quality.

Each Primo subwoofer comes equipped with powerful motors that provide extreme control and high output levels, even with modest power amplifiers. They were also engineered to be very flexible, performing spectacularly in sealed and vented applications.

Providing deep, rich bass performance at a consumer-minded price, the Primo are the best performing subwoofers in their category.

MODEL	UNIT SIZE (Inch)	NOMINAL IMPEDANCE (OHMS)	POWER HANDLING (WRMS)	PEAK POWER HANDLING (10MS) (W)	SENSITIVITY (2.83V/1M) (dB)	FREQUENCY RESPONSE (Hz)
Primo 124	12" Diameter	4	350	700	91	20-900
Primo 104	10" Diameter	4	300	600	90	22-900
Primo 804	8" Diameter	4	250	500	89	25-900





MPS AMPLIFIERS

The MPS series amplifiers integrate seamlessly with Morel speaker systems, powering music the way it's supposed to be heard. Engineered to a higher level, comparably priced amplifiers simply cannot match the high-fidelity sound quality of the MPS series.

Available in 4 and 5-channel, as well as a monoblock option, each model uses superb components and thoughtful design. Top mounted level and filter controls are concealed beneath a removable chassis panel, making for easy adjustments. Noise eliminating balanced line inputs can receive signal from most sources, including high-level inputs up to 20 volts on mono channels. Other integration features consist of auto turn-on thru signal sensing, as well as and DC offset sensing, making the MPS amplifiers friendly for integrating with factory audio systems.

The MPS amplifiers will provide you with the seamless audio experience you've been waiting for. Let them lead the charge while you sit back and enjoy the drive.

MPS AMPLIFIERS	MPS 4.400	MPS 1.550	MPS 5.950
RMS POWER @ 14V			
4 Ohm	4 x 70W	1 x 350W	4 x 70W + 1 x 350W
2 Ohm	4 x 100W	1 x 550W	4 x 100W + 1 x 550W
SPECIFICATIONS			
THD+N	0.05%	0.15%	0.05% (main) 0.15% (sub)
Frequency Response (main)	10Hz-30kHz	N/A	10Hz-30kHz
Frequency Response (sub)	N/A	10-220Hz	N/A
S/N Ratio (Rated Power, A-weighted)	100dB	100dB	100dB
Damping Factor	>100	>150	>100 (main), >150 (sub)
Selectable Input Range	Yes (x1/x2)	Yes (x1x4)	Yes (x1/x2/x4)
PREAMP			
Filters (main)	HP/LP, 40Hz-400Hz	N/A	HP/LP, 40Hz-400Hz
Filters (sub)	N/A	LP, 40-220Hz	LP, 40-220Hz
Subwoofer Level Control	No	YES, 0-20dB	YES, 0-20dB
Subsonic Filter	No	Selectable Off/25Hz/35Hz	Selectable Off/25Hz/35Hz
DIMENSIONS			
Height (H)	2" (51mm)	2" (51mm)	2" (51mm)
Width (W)	6.7" (170mm)	6.7" (170mm)	6.7" (170mm)
Length (L)	12.39" (314.5mm)	8.44" (214.5mm)	18.29" (464.5mm)





INTEGRATION

Bespoke DirectFit speaker systems
for exceptional HiFi sound quality

BMW INTEGRATION

The tailor-made BMW Integration series are offered in two performance levels – REFERENCE for the audio purists, and PERFORMANCE for those seeking superior, affordable upgrades. Each of the speaker systems use Morel’s unique DirectFit mounts and plug-and-play wire harness speaker systems for a true drop-in solution that requires no cutting. Regardless which level you choose, the BMW Integration systems are guaranteed to deliver a truly dynamic listening experience for your modern BMW. Also fits many Mini models.

The IR-BMW systems were engineered to deliver true audiophile levels of performance. Intended to be used with aftermarket amplification, each IR speaker uses our powerful Hybrid magnet systems with large EVC motors, giving them unmatched resolution, tonality and power handling. DirectFit ensures getting the highest-fidelity sound in your BMW is easily done.

The IP-BMW plug-and-play speakers systems deliver a truly dynamic listening experience with the warmth and detail our speakers are renowned for. Engineered to be highly efficient, these systems perform astonishingly well with OEM amplification, yet use a robust design that allows for modest power aftermarket amplification. With the IP-BMW, getting high-performance sound in your vehicle has never been easier or more accessible.

MODEL	SIZE & CONFIGURATION	POWER HANDLING (WRMS)	PEAK POWER (W)	SENSITIVITY (2.83V/1M) (dB)	FREQUENCY RESPONSE (Hz)
IR-BMW42	4" 2-way	100	300	92	50-25,000
IR-BMW4INT	4" Point Source	80	250	90	80-25,000
IP-BMW42	4" 2-way	50	120	89	80-22,000
IP-BMW4C	4" Coaxial	40	120	89	80-22,000
IP-BMWSUB82	8" Subwoofer 2Ω	180	500	84	20-110



TWEETER DESIGN AND TECHNOLOGY

Innovative technology and a distinct design are at the heart of Morel's R&D philosophy. Our expansive know-how and total control over the entire design and manufacturing process, allowed us to develop products that effectively overcome the acoustic challenges of car audio and deliver the most innovative and best natural sounding speakers.

The following are some of the iconic technological traits that have become the foundation of Morel speaker designs:



LOTUS GRILLE
Inspired by the Lotus flower, engineered to offer an acoustic transparent solution to protect the loudspeakers whilst offering a beautiful design element. The specific pattern minimizes the "horn" effect found in traditional grilles.

IMPROVED DISPERSION WAVEGUIDE (IDW)
Designed to enhance sound dispersion while controlling diffraction and phase error, the IDW audibly improves coherency, transparency and detail in the high frequency bandwidth.

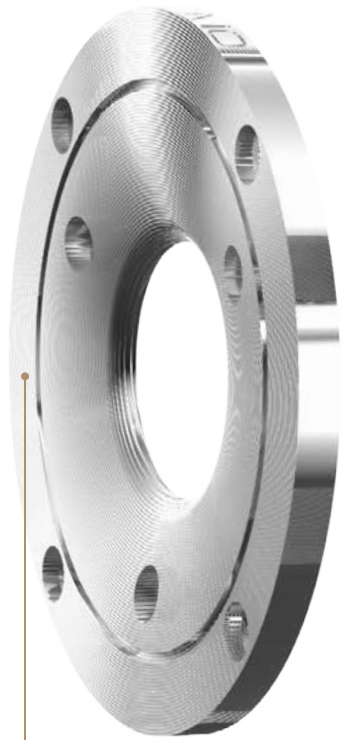

TALL DOME GEOMETRY
A specially designed tall dome uses a consistent radius to ensure wide dispersion and excellent off-axis performance.

ACUFLEX™ TECHNOLOGY
A specially engineered damping compound hand-applied to the soft domes, adding rigidity and damping, which greatly improves the clarity and bandwidth of the tweeter. The Acuflex™ diaphragm exhibits controlled cancelling break up (accurate-flexing), meaning each break-up mode is counteracted by another in the opposite direction, enabling smooth frequency response.



TITANIUM BOBBIN
Titanium bobbin (voice coil body) is known for its high rigidity, lightweight, heat transfer and conductive characteristics. Our R&D team was able to decrease eddy currents inside the magnetic gap, improve heat dissipation considerably, lower distortion and improve power handling. Despite the tremendous cost and new sophisticated manufacturing processes, the titanium bobbin delivered a tonally balanced, highly accurate, and exceptionally fast transient transducer.

HEXATECH™ ALUMINIUM VOICE COIL
Made from 100% aluminum wire shaped like a honeycomb, the Hexatech™ voice coil reduces air gaps in the coil windings, thereby increasing efficiency by up to 20%.

UNDER-HUNG VOICE COIL
An under-hung voice coil features a voice coil winding height shorter than the magnetic gap. This means the voice coil is positioned within the magnetic energy field at all times leading to greater articulation and transient response.



EXTERNAL VOICE COIL (EVC)™ TECHNOLOGY
Morel speakers with EVC™ technology utilize voice coils that are up to three times larger than those used in conventional loudspeakers, enabling improved heat dissipation, power handling and linearity. The EVC™ design moves the magnetic motor system to within the voice coil, eliminating stray magnetic flux by effectively directing all the magnetic energy to the voice coil. The EVC architecture is over 90% more efficient than conventional design, magnetically shielded, and highly compact.

ELECTRO-MAGNETIC LINEARITY OFFSET (ELO)
Transducers generate eddy (electro-magnetic) currents that force asymmetry in the magnetic flux. These currents are largely responsible for non-linearity and intermodulation distortion in a speaker. To offset this phenomenon, a copper shorting ring is placed on the top-plate and pole-piece to counter the magnetic flux modulation created by eddy currents, helping to reduce distortion and smooth frequency response.



SHIELDED MAGNET TECHNOLOGY
The modern car environment is highly sensitive to stray magnetic fields. Vehicles now use several computer control devices throughout the car, and conventional non-shielded speakers can be a threat to the vehicle's electrical integrity. Morel speakers featuring the company's EVC™ technology are more than 90% shielded—safe for installation in today's high-tech vehicles.

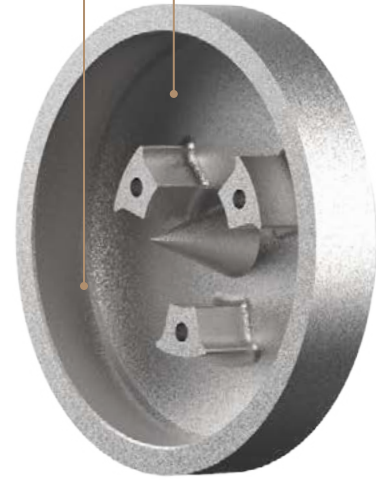

INTEGRATED REAR CHAMBER (IRC)
A low resonance frequency of the tweeter is critical in order to achieve a low crossover point, flat frequency response, and a natural sound reproduction. The highly damped integrated rear chamber (IRC) was designed to decompress the air modulation behind the tweeter diaphragm.

MAGNET TECHNOLOGY
Morel's experience in motor design has allowed it to harness the magnetic energy in extremely effective manners. There are four key motor systems used –High Grade Ferrite, Neo motor (NMM), double magnet (DMM), and Hybrid motor (HMM) systems. Each system is designed to achieve a very precise balance of size, weight, and magnetic flux to ensure optimization of the electro magnetics characteristics for each transducer.

WOOFER DESIGN AND TECHNOLOGY

SURROUND

The surround plays a major role in setting the linearity and stability of the cone-assembly. Great effort is made to carefully engineer the geometry and stiffness of each surround based on the intended use. Our surrounds employ a wide range of high-grade materials such as natural rubber and foam composite to ensure accuracy and linearity.



LOTUS GRILLE

Inspired by the Lotus flower, engineered to offer an acoustic transparent solution to protect the loudspeakers whilst offering a beautiful design element. The specific pattern minimizes the "horn" effect found in traditional grilles.

TRIPLE LAYER COMPOSITE (TLC)

An advanced one-piece cone structure consisting of a woven carbon-fiber top skin, a Rohacell™ foam core and a non-woven carbon fiber skin beneath. This proprietary cone structure offers the ultimate balance of weight, ultra-high stiffness and high self-damping characteristics.

HEXATECH™ ALUMINIUM VOICE COIL

Made from 100% aluminum wire shaped like a honeycomb, the Hexatech™ voice coil reduces air gaps in the coil windings, thereby increasing thermal efficiency by up to 20%.

TITANIUM BOBBIN

Titanium bobbin (voice coil body) is known for its high rigidity, light weight, heat transfer and conductive characteristics. Our R&D team was able to decrease eddy currents inside the magnetic gap, improve heat dissipation considerably, lower distortion and improve power handling. Despite the tremendous cost and new sophisticated manufacturing processes, the titanium bobbin delivered a tonally balanced, highly accurate, and exceptionally fast transient transducer.

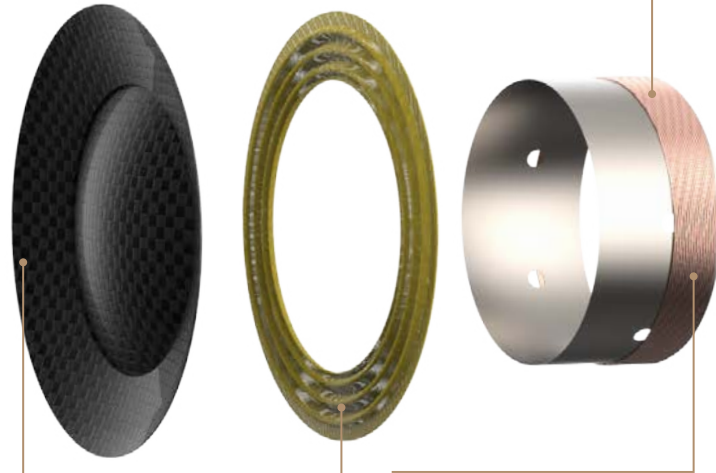

EXTERNAL VOICE COIL (EVC)™ TECHNOLOGY

Morel speakers with EVC™ technology utilize voice coils that are up to three times larger than those used in conventional loudspeakers, enabling improved heat dissipation, power handling and linearity. The EVC™ design moves the magnetic motor system to within the voice coil, eliminating stray magnetic flux by effectively directing all the magnetic energy to the voice coil. The EVC architecture is over 90% more efficient than conventional design, magnetically shielded, and highly compact.

UNDER-HUNG VOICE COIL

An under-hung voice coil features a voice coil winding height shorter than the magnetic gap. This means the voice coil is positioned within the magnetic energy field at all times leading to greater articulation and transient response.

PFS™ - PROGRESSION FIELD SYMMETRY ENGINEERING

Produces longer linear excursion enabling the spider and surround to reach optimal performance especially at high output levels by progressively acting as "shock absorbers" to prevent voice coil displacement and bottoming.

ELECTRO-MAGNETIC LINEARITY OFFSET (ELO)

Transducers generate eddy (electromagnetic) currents that force asymmetry in the magnetic flux. These currents are largely responsible for non-linearity and intermodulation distortion in a speaker. To offset this phenomenon, a copper shorting ring is placed on the top-plate and pole-piece to counter the magnetic flux modulation created by eddy currents, helping to reduce distortion and smooth frequency response.

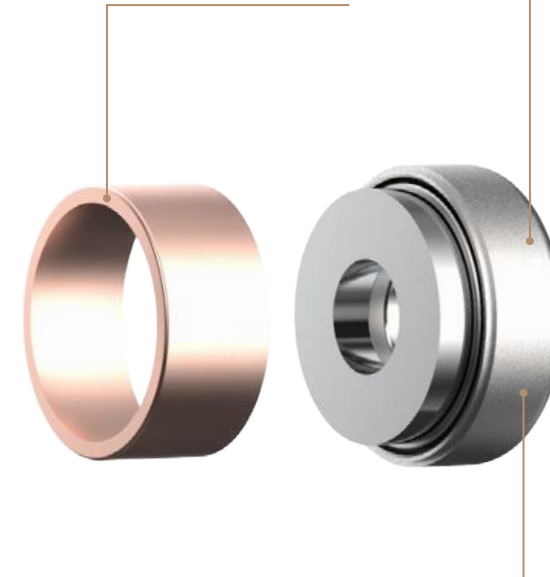

SHIELDED MAGNET TECHNOLOGY

The modern car environment is highly sensitive to stray magnetic fields. Vehicles now use several computer control devices throughout the car, and conventional non-shielded speakers can be a threat to the vehicle's electrical integrity. Morel speakers featuring the company's EVC™ technology are more than 90% shielded—safe for installation in today's high-tech vehicles.

MAGNET TECHNOLOGY

Morel's experience in motor design has allowed it to harness the magnetic energy in extremely effective manners. There are four key motor systems used –High Grade Ferrite, Neo motor (NMM), double magnet (DMM), and Hybrid motor (HMM) systems. Each system is designed to achieve a very precise balance of size, weight, and magnetic flux to ensure optimization of the electro magnetics characteristics for each transducer.



C.A.R. FILTER™ (CONTROLLED ACOUSTIC RESISTANCE)

The C.A.R. Filter™ improves the acoustic loading by controlling airflow within the driver, mimicking the effects of a cabinet while improving power handling by 30%. This provides greater control over the cone movement for improved bass dynamics.

UNIFLOW™ CHASSIS

An open design that is aerodynamically efficient to optimize venting and decompression allowing sound waves to flow uniformly and smoothly. Its geometric shape also eliminates interference with the woofer's moving components, enabling the use of a low-profile spider for greater support and stability.

unleash **the music**



Miriam Cabessa was born in Morocco, raised in Israel, and has lived and worked in New York City since 2000. Her slow action painting has been internationally recognized since 1997 when she represented Israel at the Venice Biennale. Over the past two decades, she has abstained from using brushes, opting to make marks with objects and her body. Her imagery ranges from organic to mechanistic with surfaces that are both haptically handmade and digitally serene. Miriam has shown extensively in the U.S., Europe, and Israel.



www.morelhifi.com