

P U N C H[®]

P2

SPEAKERS

PM262 • PM262B • PM262X
PM2652 • PM2652B • PM2652X
PM282 • PM282B • PM282X



Serial Number: _____

Date of Purchase: _____

Introduction

Dear Customer,

Congratulations on your purchase of the world's finest brand of audio products. At Rockford Fosgate we are fanatics about musical reproduction at its best, and we are pleased you chose our product. Through years of engineering expertise, hand craftsmanship and critical testing procedures, we have created a wide range of products that reproduce music with all the clarity and richness you deserve.

For maximum performance we recommend you have your new Rockford Fosgate product installed by an Authorized Rockford Fosgate Dealer, as we provide specialized training through Rockford Technical Training Institute (RTTI). Please read your warranty and retain your receipt and original carton for possible future use.

Great product and competent installations are only a piece of the puzzle when it comes to your system. Make sure that your installer is using 100% authentic installation accessories from Rockford Fosgate in your installation. Rockford Fosgate has everything from RCA cables and speaker wire to power wire and battery connectors. Insist on it! After all, your new system deserves nothing but the best.

To add the finishing touch to your new Rockford Fosgate image, order your Rockford accessories, which include everything from T-shirts to hats.

Visit our web site for the latest information on all Rockford products;

www.rockfordfosgate.com

or, in the U.S. call 1-800-669-9899 or FAX 1-800-398-3985. For all other countries, call +001-480-967-3565 or FAX +001-480-966-3983.

Table of Content

2	Introduction
3-4	Specifications
5	Installation
	Installation Considerations
	Mounting
6-7	Additional Languages
	French
	Spanish
	German
	Italian
8	Limited Warranty Information

If, after reading your manual, you still have questions regarding this product, we recommend that you see your Rockford Fosgate dealer. If you need further assistance, you can call us direct at **1-800-669-9899**. Be sure to have your serial number, model number and date of purchase available when you call.

PRACTICE SAFE SOUND

Continuous exposure to sound pressure levels over 100dB may cause permanent hearing loss. High powered auto sound systems may produce sound pressure levels well over 130dB. Use common sense and practice safe sound.

PRATIQUEZ UNE ÉCOUTE SANS RISQUES

Une exposition continue à des niveaux de pression acoustique supérieurs à 100 dB peut causer une perte d'acuité auditive permanente. Les systèmes audio de forte puissance pour auto peuvent produire des niveaux de pression acoustique bien au-delà de 130 dB. Faites preuve de bon sens et pratiquez une écoute sans risques

PRACTIQUE EL SONIDO SEGURO

El contacto continuo con niveles de presión de sonido superiores a 100 dB puede causar la pérdida permanente de la audición. Los sistemas de sonido de alta potencia para automóviles pueden producir niveles de presión de sonido superiores a los 130 dB. Aplique el sentido común y practique el sonido seguro.

PRAKTIZIEREN SIE SICHEREN SOUND

Fortgesetzte Geräuschdruckpegel von über 100 dB können beim Menschen zu permanentem Hörverlust führen. Leistungsstarke Autosoundsysteme können Geräuschdruckpegel erzeugen, die weit über 130 dB liegen. Bitte wenden Sie gesunden Menschenverstand an und praktizieren Sie sicheren Sound.

OSSERVATE LE REGOLE DEL SUONO SENZA PERICOLI

La costante esposizione a livelli di pressione acustica al di sopra dei 100dB possono causare la perdita permanente dell'udito. I sistemi audio ad alta potenza possono produrre livelli di pressione acustica ben superiori ai 130dB. Si consiglia il buon senso e l'osservanza delle regole del suono senza pericoli

Safety

This symbol with "WARNING" is intended to alert the user to the presence of important instructions. Failure to heed the instructions will result in severe injury or death.



WARNING

This symbol with "CAUTION" is intended to alert the user to the presence of important instructions. Failure to heed the instructions can result in injury or unit damage.



CAUTION

- To prevent injury and damage to the unit, please read and follow the instructions in this manual. We want you to enjoy this system, not get a headache.
- If you feel unsure about installing this system yourself, have it installed by a qualified Rockford Fosgate technician.
- Before installation, disconnect the battery negative (-) terminal to prevent damage to the unit, fire and/or possible injury.

Model	PM262	PM262B	PM262X	PM2652	PM2652B	PM2652X	PM282	PM282B	PM282X
Nominal Diameter - inch (mm)	6 (152)	6 (152)	6 (152)	6.5 (165)	6.5 (165)	6.5 (165)	8 (203)	8 (203)	8 (203)
Description	2-Way	2-Way	2-Way	2-Way	2-Way	2-Way	2-Way	2-Way	2-Way
Nominal Impedance (Ohms)	4Ω	4Ω	4Ω	4Ω	4Ω	4Ω	4Ω	4Ω	4Ω
Frequency Response (Hz)	53-22kHz	53-22kHz	53-22kHz	49-22kHz	49-22kHz	49-22kHz	48-22kHz	48-22kHz	48-22kHz
Voice Coil Diameter - inch (mm)	1.0 (25.4)	1.0 (25.4)	1.0 (25.4)	1.0 (25.4)	1.0 (25.4)	1.0 (25.4)	1.25 (32.3)	1.25 (32.3)	1.25 (32.3)
Power Handling - Watts (RMS/Peak)	75/150	75/150	75/150	85/170	85/170	85/170	100/200	100/200	100/200
Fs - Free Air Resonance (Hz)	60	60	60	65.5	65.5	65	50	50	50
Qts	0.64	0.64	0.64	0.79	0.79	0.80	0.53	0.53	0.53
Vas - cu. ft. (Liter)	0.445 (12.6)	0.445 (12.6)	0.445 (12.6)	0.417 (11.8)	0.417 (11.8)	0.417 (11.8)	1.06 (30)	1.06 (30)	1.06 (30)
Sensitivity (1W/1M)	88dB	88dB	88dB	89dB	89dB	89dB	90dB	90dB	90dB
Sensitivity (2.83V/1M)	91dB	91dB	91dB	92dB	92dB	92dB	93dB	93dB	93dB
Xmax - inch (mm)	0.2 (5)	0.2 (5)	0.2 (5)	0.2 (5)	0.2 (5)	0.2 (5)	0.28 (7)	0.28 (7)	0.28 (7)
Mounting Diameter	5.2 (131)	5.2 (131)	5.2 (131)	5.3 (136)	5.3 (136)	5.3 (136)	7.1 (180)	7.1 (180)	7.1 (180)
Mounting Depth	2.8 (71)	2.8 (71)	2.8 (71)	2.8 (72)	2.8 (72)	2.8 (72)	3.4 (87)	3.4 (87)	3.4 (87)
Grille/Trim Ring	YES	YES	YES	YES	YES	YES	YES	YES	YES

See page 4 for additional dimensions



CEA 2031

Power handling on Rockford Fosgate speakers conform to CEA-2031 industry standards. This means your speaker has the capacity to handle power under continuous demand, not instantaneous power handling that over time can damage voice coils.



VERIFIED WITH KLIPPEL

To adorn the 'Verified with Klippel' mark, the qualifying company's loudspeaker engineering personnel must be trained and certified by Klippel prior to using the three separate Klippel systems to design, develop and test. Rockford Fosgate has made the investment in Klippel to deliver the best possible speakers and subwoofers to their customers.

Specifications

PM262/PM262B

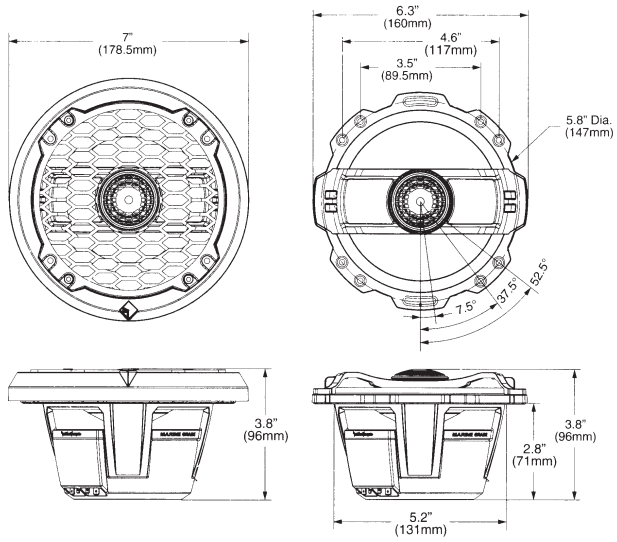

PM262X

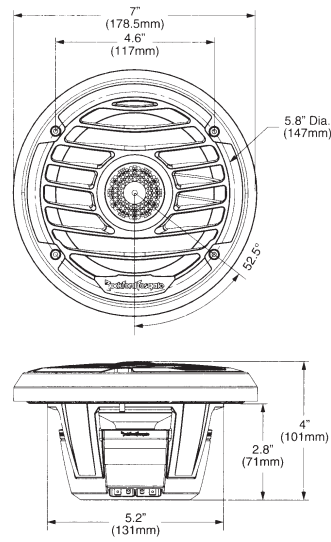

PM2652/PM2652B

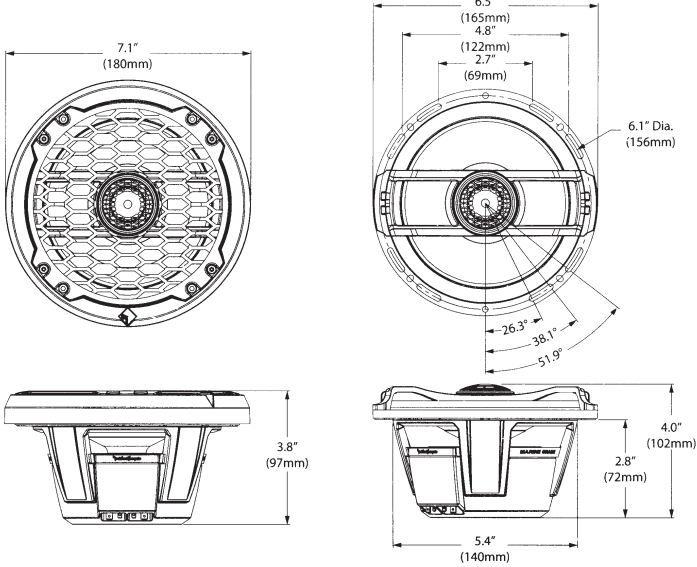

PM2652X

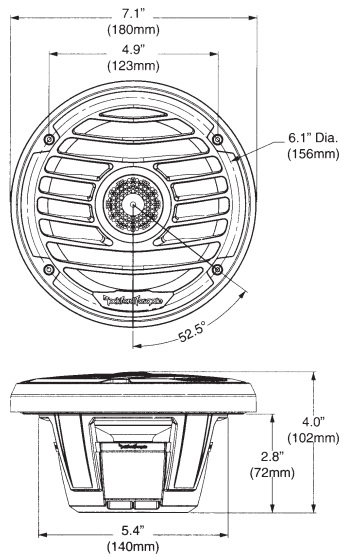

PM282/PM282B

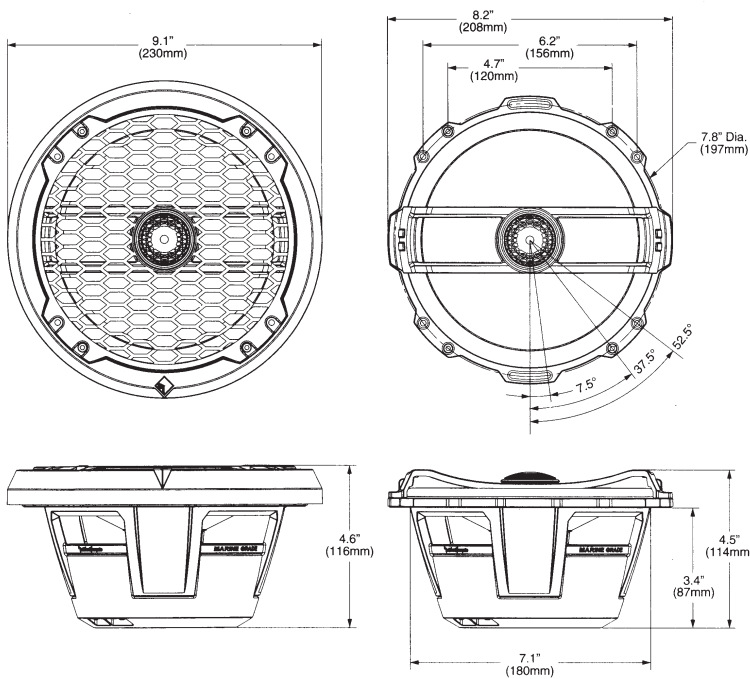

PM282X

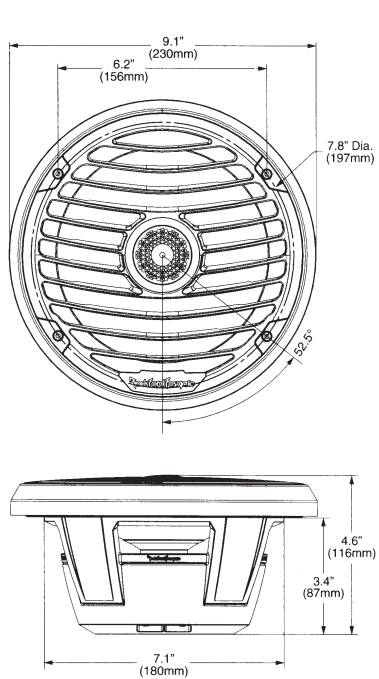

Contents

- (1) Pair Marine Grade Speakers
- (1) Pair Removable Trim Rings (Non "X" models)
- (12) Socket head stainless screws (PM2 models)
- (8) Socket head stainless screws (PM2X models)
- (1) Socket head driver bit

Installation Considerations

Before beginning any installation, follow these simple rules:

1. Be sure to carefully read and understand the instructions before attempting to install these speakers.
2. For safety, disconnect the negative lead from the battery prior to beginning the installation.
3. For easier assembly, we suggest you run all wires prior to mounting your speakers in place.
4. Use high quality connectors for a reliable installation and to minimize signal or power loss.
5. Think before you drill! Be careful not to cut or drill into gas tanks, fuel lines, brake or hydraulic lines, vacuum lines or electrical wiring when working on any vehicle. If installation in a boat, take care not to cut or drill through the main hull.
6. Never run wires underneath the vehicle. Running the wires inside the vehicle or hull area provides the best protection.
7. Avoid running wires over or through sharp edges. Use rubber or plastic grommets to protect any wires routed through metal, especially the firewall.

Mounting

1. Determine where the speakers will be mounted. Ensure an area large enough for the speaker to mount evenly. Be sure that the mounting location is deep enough for the speaker to fit; if mounting in a door, operate all functions (windows, locks, etc.) through their entire operating range to ensure there is no obstruction.
2. Refer to the specification chart to determine the proper diameter hole to cut for your speaker model. Cutting and mounting templates can be found at www.rockfordfosgate.com.
3. Mark the locations for the mounting screws. Drill the holes with a 1/8" bit.
4. Feed the speaker wires through the cutout and connect to the speaker terminals. Be sure to observe proper polarity when connecting the wires. The speaker's positive terminal is indicated with a "+".
5. Fit the trim ring over the speaker and mount into place using four (4) screws.
6. Tighten the screws until the speaker is snug in place to prevent rattling. Do not over tighten the screws.

Example of standard installation

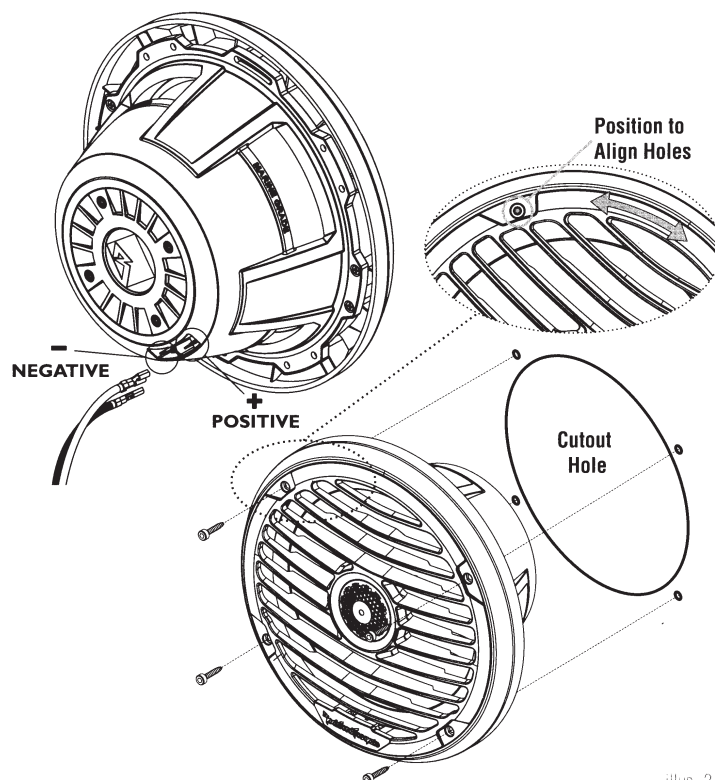
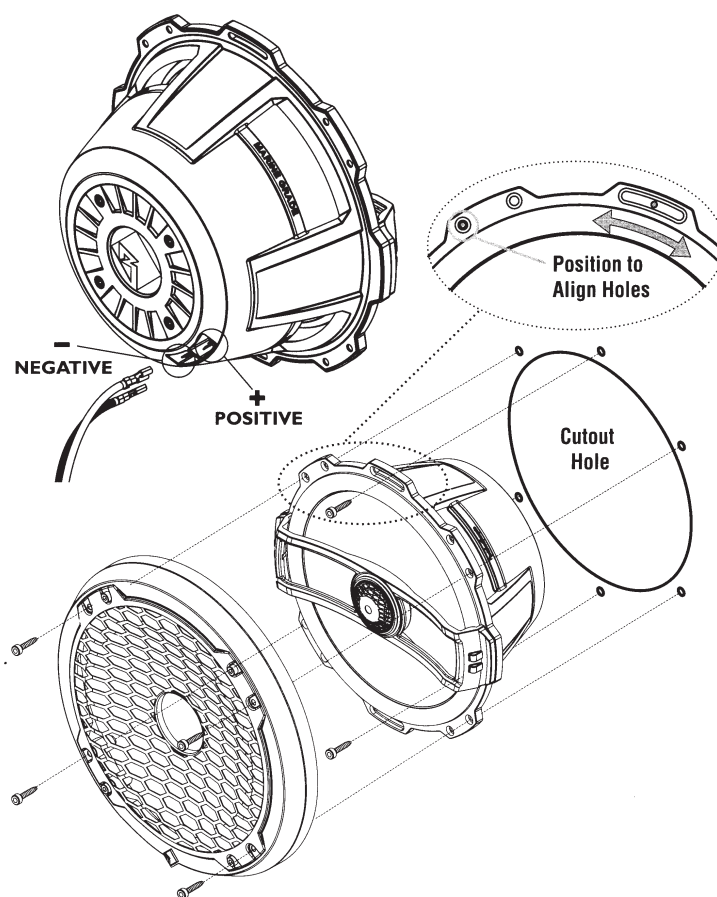

Considérations Concernant L'installation

Avant de commencer l'installation, suivez les règles ci-dessous:

1. Veillez à bien lire et comprendre les instructions avant d'essayer d'installer les haut-parleurs.
2. Par mesure de sécurité, débranchez le fil négatif de la batterie avant de commencer l'installation.
3. Pour faciliter le montage des haut-parleurs, il est conseillé d'installer tous les câbles au préalable.
4. Utilisez des connecteurs de haute qualité pour assurer une installation fiable et réduire au minimum la perte de signal ou de puissance.
5. Réfléchissez bien avant de percer. Veillez à ne pas couper ou percer le réservoir d'essence, le câblage électrique ou les conduites de carburant, de freinage hydraulique ou de dépression en travaillant sur un véhicule. En cas d'installation sur un bateau, veillez à ne pas couper ou percer la coque principale.
6. Ne jamais faire passer de fils sous le véhicule. Leur installation à l'intérieur du véhicule ou de la coque assure la meilleure protection.
7. Évitez de faire passer des fils sur des bords tranchants ou dans des orifices à arêtes vives. Utilisez des bagues en caoutchouc ou en plastique pour protéger les fils traversant une plaque de métal, notamment le tablier. Emplacements De Montage

Montage

1. Déterminez l'emplacement des haut-parleurs. Veillez à ce que la surface plane soit assez grande pour assurer un contact uniforme du haut-parleur. Vérifiez que l'emplacement est assez profond pour le haut-parleur ; en cas de montage dans une portière, actionnez toutes les commandes (fenêtres, serrures, etc.) jusqu'aux extrémités de leurs courses pour vous assurer qu'il n'y a pas d'obstruction.
2. Consultez le tableau des caractéristiques pour déterminer le diamètre de l'orifice à découper pour votre modèle de haut-parleur. Le gabarit fourni donne aussi le bon diamètre de découpe. Les gabarits de coupe et de montage sont disponibles sur la page www.rockfordfosgate.com/rfttech.
3. Marquez l'emplacement des vis de montage. Percez les trous avec une mèche de 1/8 de pouce (3,2 mm).
4. Faites passer les fils de haut-parleur à travers l'orifice découpé et branchez-les aux bornes du haut-parleur. Veillez à bien respecter la polarité lors du branchement. La borne positive du haut-parleur est indiquée par un « + ».
5. Disposez l'anneau de garniture sur le haut-parleur et fixez-le avec quatre (4) vis.
6. Serrez les vis jusqu'à ce que le haut-parleur soit bien ajusté, de façon à prévenir tout cliquetis, mais évitez tout serrage excessif.

Consideraciones para la instalación

Antes de comenzar cualquier instalación, siga estas simples normas:

1. Asegúrese de leer cuidadosamente y de entender las instrucciones antes de tratar de instalar estos altavoces.
2. Por seguridad, desconecte el conductor negativo de la batería antes de comenzar la instalación.
3. Para facilitar el montaje, sugerimos que tienda todos los cables antes de montar sus altavoces en su sitio.
4. Utilice conectores de alta calidad para tener una instalación confiable y para reducir al mínimo las pérdidas de señal o de potencia.
5. ¡Piense siempre antes de perforar! Tenga cuidado de no cortar ni perforar en tanques de combustible, tuberías de combustible, frenos o hidráulicas, tuberías de vacío o cableado eléctrico al trabajar en un vehículo. Si la instalación se hace en un bote, tenga cuidado de no cortar ni perforar a través del casco principal.
6. Nunca tienda cables abajo del vehículo. Tender los cables adentro del vehículo o casco proporciona la mejor protección.
7. Evite tender cables arriba o a través de bordes filosos. Use arandelas aislantes de caucho para proteger los cables tendidos a través de metal, especialmente la mampara cortafuegos. Montage

Montaje

1. Determine adónde se montará los altavoces. Asegúrese de que haya un área suficientemente grande para montar de manera plana el altavoz. Asegúrese de que el lugar de montaje sea suficientemente profundo para que quepa el altavoz, si se monta en una puerta, accione todas las funciones (ventanas, cerradura, etc.) en toda su gama de funcionamiento para asegurarse de que no haya obstrucciones.
2. Consulte la tabla de especificaciones para determinar cuales son los diámetros correctos para el agujero a cortar para su modelo de altavoz. La plantilla proporcionada también le da la medida correcta del recorte. Se puede hallar las plantillas para el corte y el montaje en www.rockfordfosgate.com/rfttech.
3. Marque las localidades para los tornillos de montaje. Perfore los agujeros usando una broca de 1/8 pulg.
4. Tienda los cables del altavoz a través del recorte y conecte a los terminales del altavoz. Asegúrese de usar la polaridad correcta al conectar los cables. El terminal positivo del altavoz está identificado con un símbolo "+".
5. Coloque el anillo de acabado arriba del altavoz y móntelo en su sitio usando cuatro (4) tornillos.
6. Apriete los tornillos hasta que el altavoz esté ajustado en su sitio para evitar vibraciones. No apriete demasiado los tornillos.

Einbauüberlegungen

Befolgen Sie vor dem Einbau diese einfachen Regeln:

1. 1. Lesen Sie die Anleitung sorgfältig, bevor Sie versuchen diese Lautsprecher einzubauen.
2. Entfernen Sie vor dem Einbau aus Sicherheitsgründen das negative Kabel von der Batterie.
3. Um die Montage zu erleichtern, empfehlen wir alle Kabel vor der Befestigung Ihrer Lautsprecher zu verlegen.
4. Verwenden Sie nur Qualitätsstecker, um einen zuverlässigen Einbau zu gewährleisten und Signal- und Stromverlust zu minimieren.
5. Denken Sie nach, bevor Sie bohren! Achten Sie darauf, nicht in den Benzintank, die Benzin-, Brems- oder hydraulischen Leitungen, Vakuulleitungen oder Elektrokabel zu schneiden oder zu bohren, wenn Sie am Fahrzeug arbeiten. Achten Sie beim Einbau in einem Boot darauf, nicht durch den Bootsrumpf zu schneiden oder zu bohren.
6. Verlegen Sie Kabel nie unter dem Fahrzeug. Die Kabel im Fahrzeug oder Bootsrumpf zu verlegen, bietet den besten Schutz.
7. Vermeiden Sie es, Kabel über scharfe Kanten zu verlegen. Verwenden Sie Gummi- oder Plastikringe, um Kabel zu schützen, die durch Metall verlegt werden (besonders die Feuerwand).

Befestigung

1. Entscheiden, wo die Lautsprecher befestigt werden sollen. Gewährleisten, dass der Platz ausreicht, um den Lautsprecher gleichmäßig zu befestigen. Gewährleisten, dass die Befestigungsstelle ausreichende Tiefe für den Lautsprecher hat; beim Einbau in einer Türe alle Funktionen (Fenster, Schloss usw.) in ihrem ganzen Bereich ausprobieren um zu gewährleisten, dass keine Blockierung eintritt.
2. Die Tabelle in den Technischen Daten gibt den richtigen Lochdurchmesser für Ihr Lautsprechermodell zum Ausschneiden an. Die beiliegende Schablone zeigt ebenfalls die richtige Ausschneidegröße an. Schneide- und Befestigungsschablonen finden Sie unter www.rockfordfosgate.com/rftech.
3. Die Stellen für die Befestigungsschrauben markieren. Die Löcher mit einer 1/8-Zoll (3,2 mm) Bohrer Spitze bohren.
4. Die Lautsprecherkabel durch das Loch führen und an den Lautsprecherausgängen anschließen. Beim Anschließen der Kabel die ordnungsgemäße Polarität beachten. Der positive Anschluss des Lautsprechers ist mit einem „+“ markiert.
5. Den Zierring über den Lautsprecher legen und mit 4 (vier) Schrauben an seinem Platz befestigen.
6. Die Schrauben anziehen, bis der Lautsprecher eng an seinem Platz anliegt, um Klappern zu verhindern. Die Schrauben nicht zu fest anziehen..

Considerazioni sull'installazione

Prima di iniziare qualsiasi operazione d'installazione, vi consigliamo di seguire queste semplici regole:

1. Assicuratevi di aver letto tutte le istruzioni con cura e di averle capite prima di effettuare qualsiasi tentativo d'installazione nei confronti dell'unità.
2. Per motivi di sicurezza, scollegate il cavo negativo dalla batteria prima di dare l'avvio all'installazione.
3. Per facilitare il montaggio, vi suggeriamo di far scorrere tutti i fili prima di montare la vostra unità nella sua ubicazione.
4. Usate connettori di alta qualità per garantire un'installazione che dà affidamento e per ridurre al minimo la perdita di segnali o di potenza.
5. State attenti prima di trapanare! Cercate di non trapanare e di non incidere i serbatoi della benzina; le condutture del carburante, dei freni, del sistema idraulico e a depressione; nonché i fili elettrici quando state lavorando su qualsiasi veicolo.
6. Non fate mai scorrere i fili sotto il veicolo. Avrete la protezione migliore facendo scorrere i fili all'interno del veicolo.
7. Evitate di far scorrere i fili sopra o attraverso delle estremità affilate. Usate guarnizioni di tenuta in gomma o in plastica per proteggere qualsiasi filo che passi attraverso del metallo, soprattutto il parafiamma.

Montaggio

1. Decidete dove montare gli altoparlanti. Assicuratevi che sia un'area abbastanza grande per poter montare l'altoparlante a livello e abbastanza profonda per poterlo collocare comodamente. Se lo montate all'interno di uno sportello, controllate tutte le funzioni (finestre, serrature, ecc.), una alla volta, per assicurarvi che non ci siano ostruzioni.
2. Fate riferimento alla tabella delle specifiche per stabilire il diametro corretto del foro che dovrete praticare per il modello del vostro altoparlante. Si possono trovare le sagome per il taglio e il montaggio presso www.rockfordfosgate.com/rftech.
3. Marcare le posizioni per le viti di montaggio. Praticare i fori con una punta da trapano di 1/8 di pollice (3,2 mm).
4. Passare i cavi del diffusore tramite l'apertura e collegarli ai terminali. Verificare che la polarità sia corretta quando si collegano i cavi. Il terminale positivo del diffusore è identificato dal „+“.
5. Adattare l'anello di finitura sul diffusore e montare in posizione servendosi delle quattro (4) viti.
6. Per evitare rumore dovuto a vibrazioni serrare le viti finché il diffusore non sia saldamente in posizione. Non serrare le viti in modo eccessivo..

Rockford Corporation offers a limited warranty on Rockford Fosgate products on the following terms:

Length of Warranty

POWER Amplifiers – 2 Years
BMW® Direct Fit Speakers – 2 Years
All other products - 1 Year
Any Factory Refurbished Product – 90 days (receipt required)

What is Covered

This warranty applies only to Rockford Fosgate products sold to consumers by Authorized Rockford Fosgate Dealers in the United States of America or its possessions. Product purchased by consumers from an Authorized Rockford Fosgate Dealer in another country are covered only by that country's Distributor and not by Rockford Corporation.

Who is Covered

This warranty covers only the original purchaser of Rockford product purchased from an Authorized Rockford Fosgate Dealer in the United States. In order to receive service, the purchaser must provide Rockford with a copy of the receipt stating the customer name, dealer name, product purchased and date of purchase.

Products found to be defective during the warranty period will be repaired or replaced (with a product deemed to be equivalent) at Rockford's discretion.

What is Not Covered

1. Damage caused by accident, abuse, improper operations, water, theft, shipping.
2. Any cost or expense related to the removal or reinstallation of product.
3. Service performed by anyone other than Rockford or an Authorized Rockford Fosgate Service Center.
4. Any product which has had the serial number defaced, altered, or removed.
5. Subsequent damage to other components.
6. Any product purchased outside the U.S.
7. Any product not purchased from an Authorized Rockford Fosgate Dealer.

Limit on Implied Warranties

Any implied warranties including warranties of fitness for use and merchantability are limited in duration to the period of the express warranty set forth above. Some states do not allow limitations on the length of an implied warranty, so this limitation may not apply. No person is authorized to assume for Rockford Fosgate any other liability in connection with the sale of the product.

How to Obtain Service

Contact the Authorized Rockford Fosgate Dealer you purchased this product from. If you need further assistance, call 1-800-669-9899 for Rockford Customer Service. You must obtain an RA# (Return Authorization number) to return any product to Rockford Fosgate. You are responsible for shipment of product to Rockford.

EU Warranty

This product meets the current EU warranty requirements, see your Authorized dealer for details.

Installation assistance available at:

RFTECH

www.rockfordfosgate.com/rftech

Printed in China

1230-60196-01-A

100615

600 South Rockford Drive • Tempe, Arizona 85281 United States
Direct: (480) 967-3565 • Toll Free: (800) 669-9899

ROCKFORDFOSGATE.COM

